

# **SINKING OPEN CELL MEDIA FILTRATION MEDIA**

Cranfield University Test Report

*Comparative performance study of  
Sinking Open Cell Media and conventional sand filtration*

*Cranfield*  
UNIVERSITY

## Executive Summary

The aim of the project has been defined to **evaluate** and **investigate** the performance of a new filter media known as **Sinking Open Cell Media** against conventional sand filters used on water bodies.

Identical experimental rigs for sand and Sinking Open Cell Media filters were assembled for comparing the **effectiveness** and **efficiency** of the filters against one another.

**Sinking Open Cell Media** achieved the target NTU value by consuming **considerably less energy** while operating at **lower pressure** and **constant flow-rate** than sand filtration.

In conclusion, **the Sinking Open Cell Media has been found to be as effective as sand in filtering water** whilst being **more cost effective** in terms of its power consumption and **more reliable** in terms of its flow rate.

*“Sinking Open Cell Media has been found to be as effective as sand in filtering water whilst being more cost effective in terms of its power consumption and more reliable in terms of its flow rate.”*

*Cranfield University Report*

## TEST SET-UP

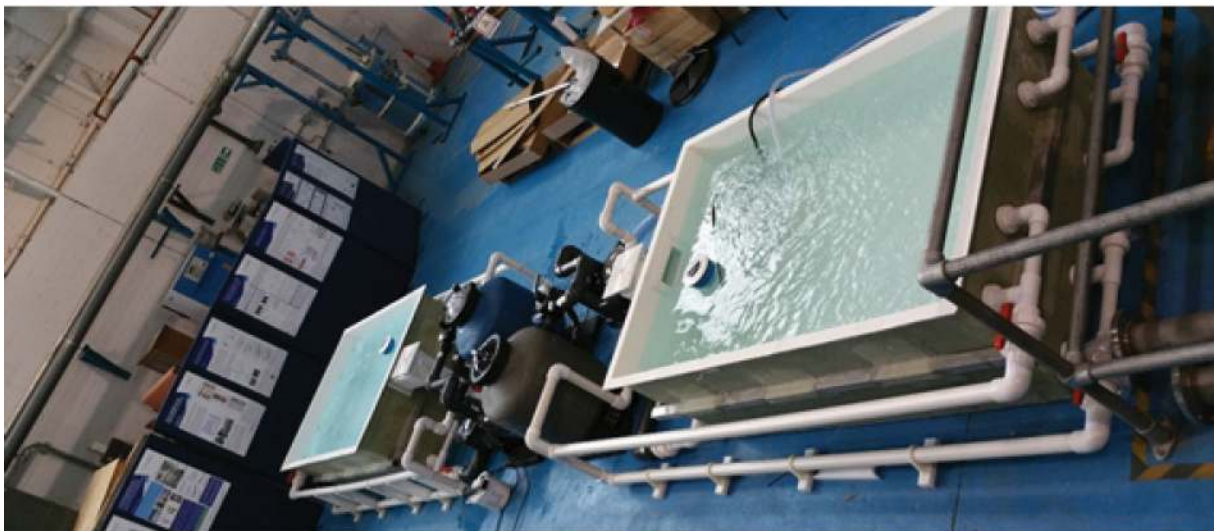

*Photographs showing set-up layout*

**Author:** Prof. Hoi Yeung Mehrdad Silatani

**Dept:** Centre for Oil & Gas Engineering, School of Energy, Environment & Agrifood, Cranfield University

**Report No:** 15/HY/633

**Date:** September 2015

## TEST SET-UP

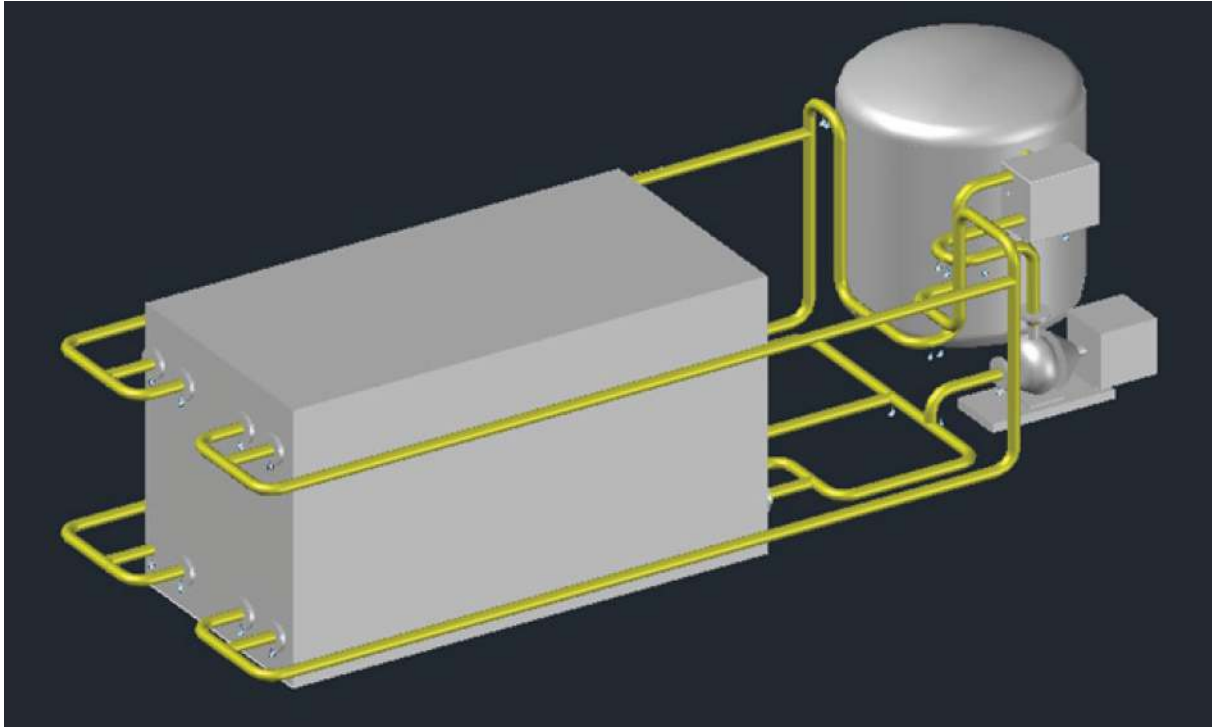

3D representation of the experimental setup

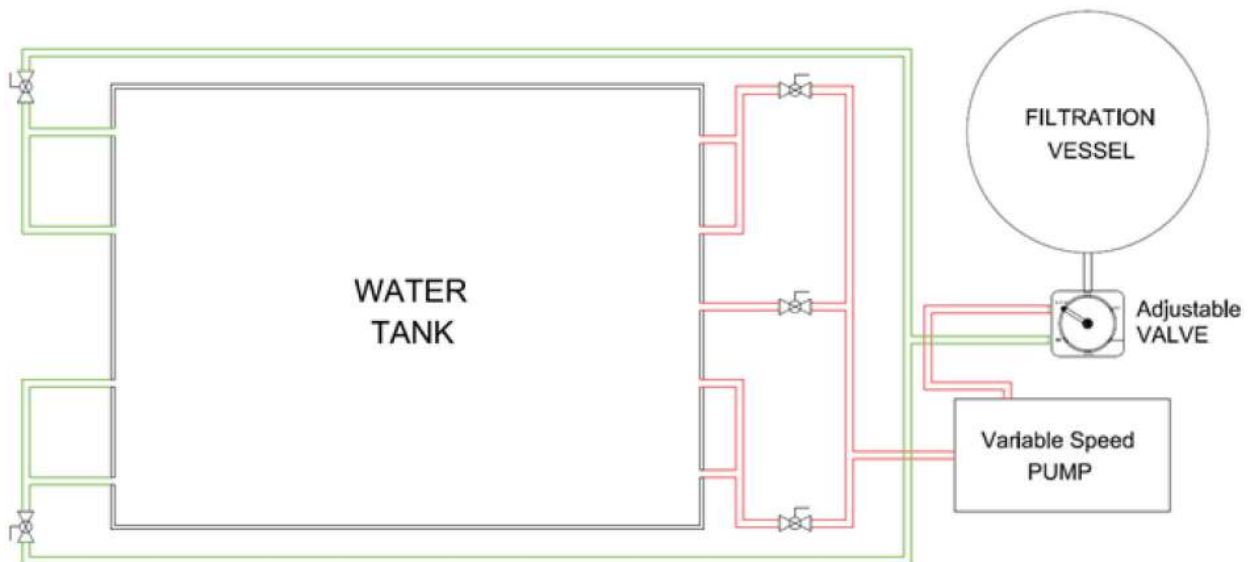

Piping layout and flow direction of each filtration system

**Author:** Prof. Hoi Yeung Mehrdad Silatani

**Dept:** Centre for Oil & Gas Engineering, School of Energy, Environment & Agrifood, Cranfield University

**Report No:** 15/HY/633

**Date:** September 2015

## INSTRUMENTATION AND PROCEDURE

### Power Consumption monitoring devices

Two identical power consumption meters were plugged into the mains upstream of the adjustable speed pumps for monitoring the pump's power usage.

### Pressure Measurement

For monitoring pressure of the filtration system, a pressure gauge was installed on top of each filtration vessel. At the point of sampling water from each tank, pressure values of each tank were logged by using the installed pressure gauges.



*Pressure gauge mounted on top of the filtration vessel*

### Flow-rate Measurement

In-line floating flow meters were installed on the downstream line of the filters, which carry filtered water back to the water tank. Similar to pressure readings, flow-rate values were logged every time a water sample was taken to measure NTU values.

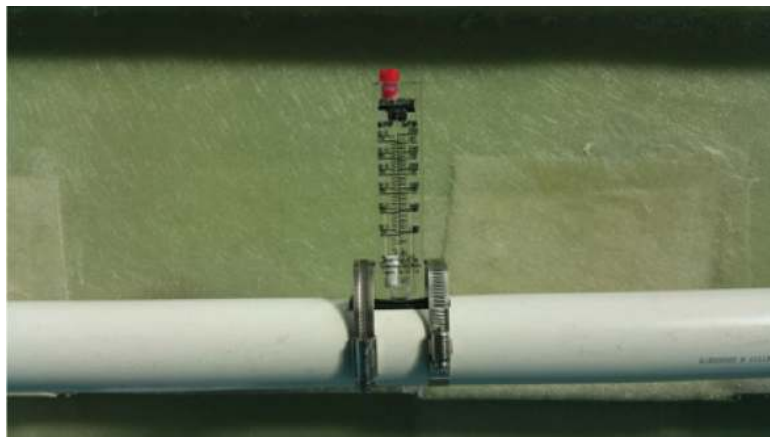

*Floating flow-meter installed downstream of the filters*

**Author:** Prof. Hoi Yeung Mehrdad Silatani

**Dept:** Centre for Oil & Gas Engineering, School of Energy, Environment & Agrifood, Cranfield University

**Report No:** 15/HY/633

**Date:** September 2015

## TEST RESULTS

Figures 10 and 11 represent the power consumption and system's pressure respectively. The increase in power consumption by sand filter can be attributed to the gradual increase in pump's speed in order to maintain a constant flow-rate.

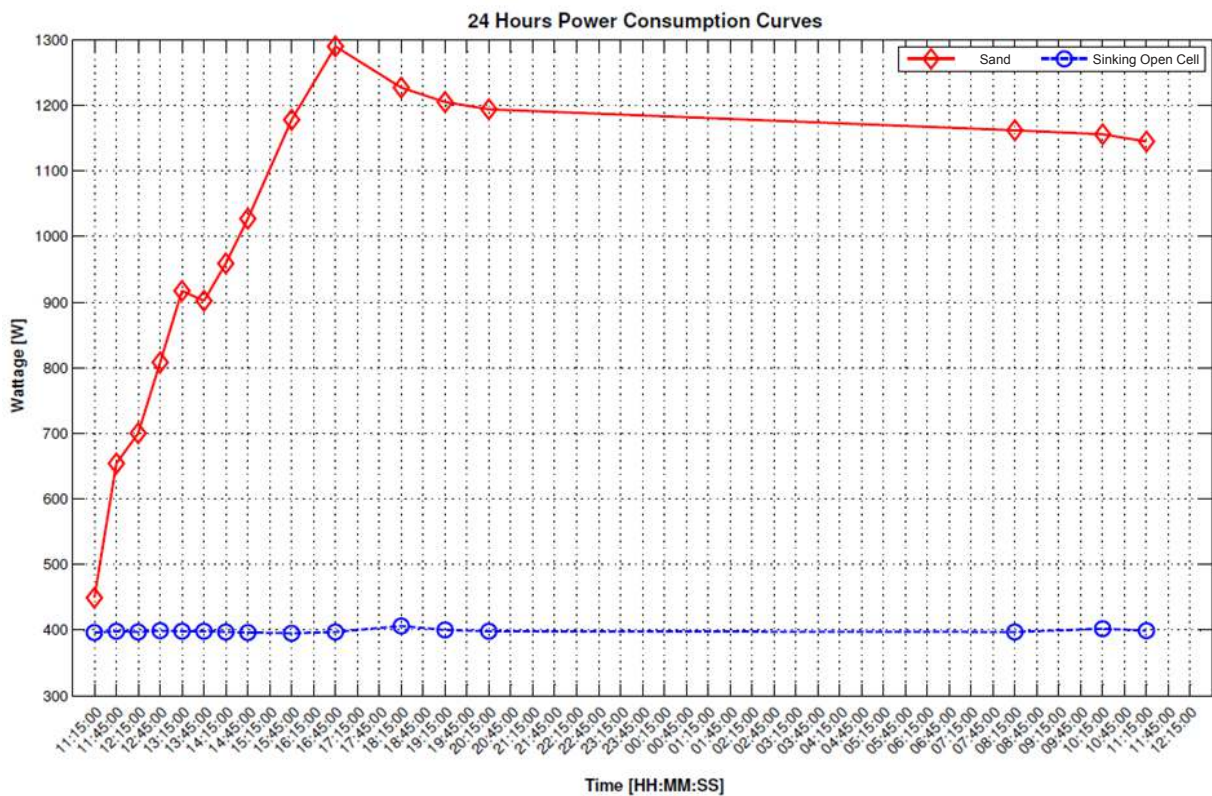

Figure 10

## TEST RESULTS (cont.)

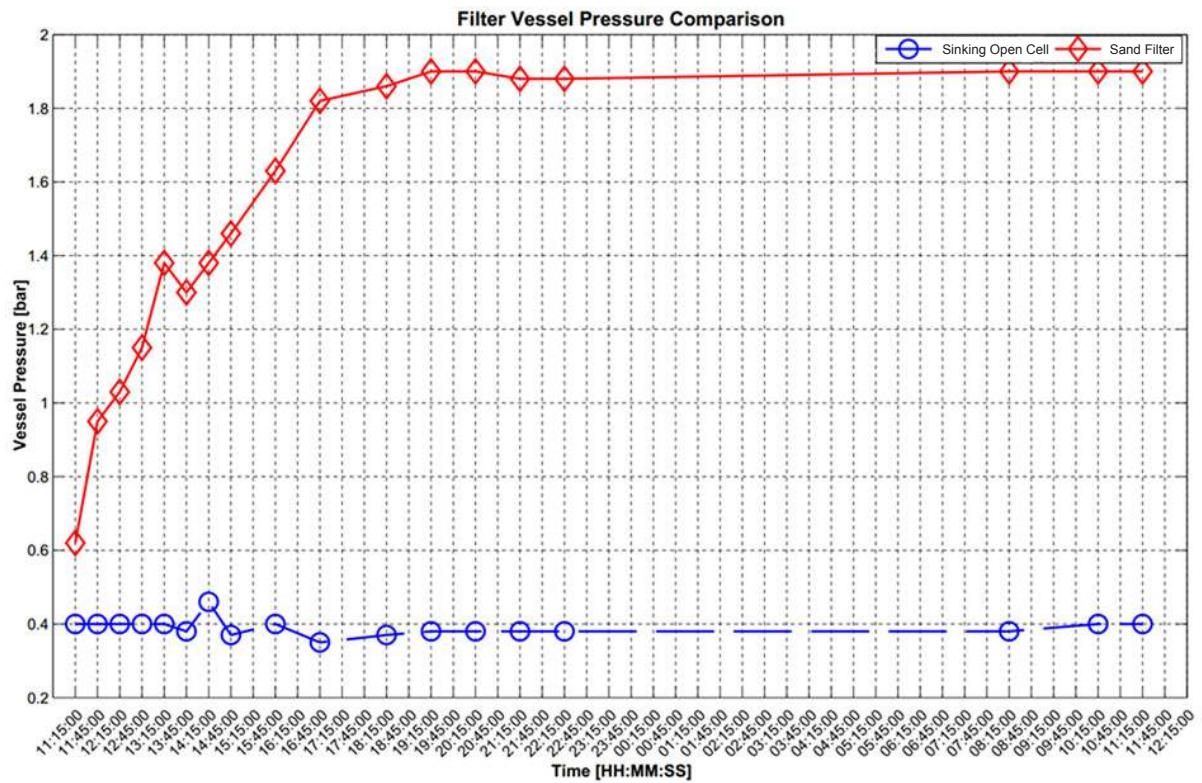

Figure 11

## TEST RESULTS

The main conclusions from conducted tests can be summarised as follows:

- Sinking Open Cell Media proved to be **as effective as sand** in reaching a target NTU value of 0.5.
- Sinking Open Cell Media has shown **far greater capacity for filtering debris** compared to sand. In scenarios that cause the sand filter to block in seconds due to the heavy debris load, **Sinking Open Cell Media continues to filter without a noticeable change in the system's pressure or flow-rate**. This signifies an advantage of Sinking Open Cell Media over sand as it requires backwashing less frequently.
- In terms of power consumption, Sinking Open Cell Media consumes **considerably less power** for delivering the same filtration performance in comparison to traditional sand.
- The Sinking Open Cell Media exhibited **constant pressure** and **flow-rate** throughout the testing period whereas sand did not.

*To sum up, by using Sinking Open Cell Media, one can expect a significant reduction in the power consumption of the system as well as greater capacity in filtering, while operating at a steady pressure and flow-rate.*



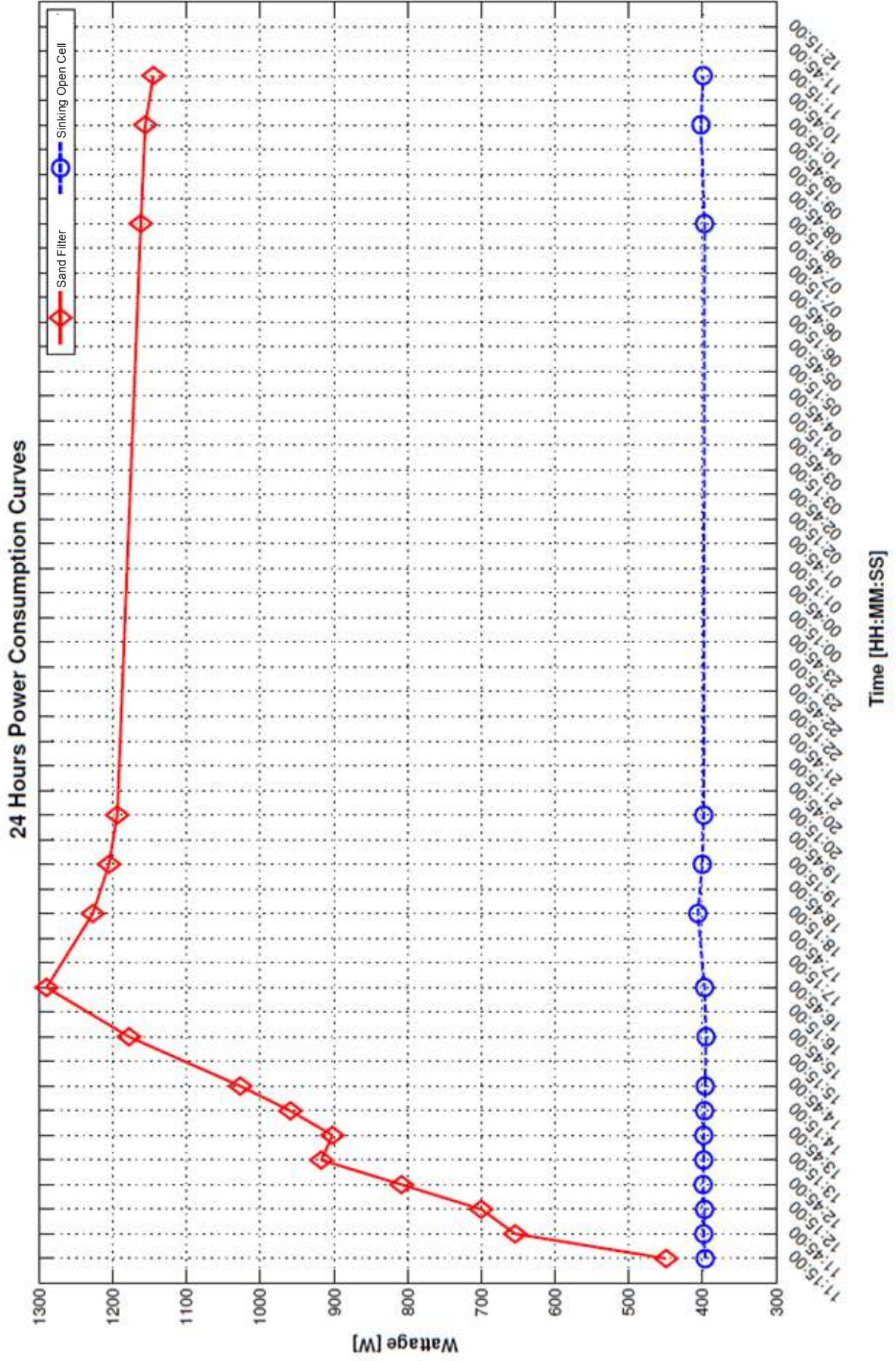

Filter Vessel Pressure Comparison

