

# PRO<sub>2</sub>

## Instructions for Use

Max 5 – Max 8 – Max 10

### Oxygen Generators

For models: 665MC, 765MC, 685MC, 785MC, 695MC, 795MC (and variants thereof)



  	<p>This device supplies highly concentrated oxygen enriched product gas that promotes rapid burning.</p> <p><b>DO NOT</b> allow smoking or open flames within the same room of this device.</p> <p>Failure to observe this warning can result in severe fire, property damage, and / or cause physical injury or death.</p>
 	<p>Oxygen accelerates the combustion of flammable substances.</p> <p><b>DO NOT</b> use oil, grease, petroleum based or other flammable products on the device.</p>
	<p>This device is intended for industrial use. It should be placed in a well-ventilated area, free from smoke and atmospheric pollution, where the intake filter ventilation is not obstructed or blocked.</p>
	<p><b>DO NOT</b> use in an explosive environment.</p> <p><b>DO NOT</b> use in a magnetic environment.</p>

	<p><b>DO NOT</b> open the device while in operation. Failure to observe this warning can result in electrical shock.</p> <p><b>DO NOT</b> remove the cabinets unless you are a qualified service technician.</p>
	<p><b>DO NOT</b> use extension cords or adapters. Use the power cord provided.</p> <p>Check that the electrical characteristics of the power outlet used match those indicated on the manufacturer's plate on the rear panel of the device.</p>
	<p>This unit may be equipped with a polarized plug. That is one blade wider than the other. If it does not fit into the outlet, reverse the plug. If it still does not fit, contact a qualified electrician. Do not defeat this safety feature.</p>
	<p>Only persons who have read and understood this entire manual should be allowed to operate the device.</p>

## 1 Glossary of Symbols

	ON (Power switched on)
	OFF (Power switched off)
	Class I (Protective Earth)
	Do Not Expose to Open Flames
	Do Not Expose to Oil or Grease

	Tools Required / Technician Only
	FRAGILE – Handle with Care
	Keep in Vertical Position
<b>IPX1</b>	Protection from vertically falling water drops

	WARNING – A hazard or unsafe practice that can result in serious injury or death if conditions are not avoided.
	Caution - A hazard or unsafe practice that can result in minor injury and / or property damage if conditions are not avoided.
	Note – Information important enough to emphasize or repeat

## 2 Purpose and Principles of Operation

This device is intended to supply oxygen for applications requiring high concentration. It produces an enriched product gas by concentrating the oxygen contained in room air.

The operation of the device begins with air being pulled into the external air intake filter. This filtered air enters the compressor via a suction resonator and fine filter. Pressurized air then exits the compressor and into an electronic valve system that directs the air into one of two tubes that contain molecular sieve (sieve beds). The molecular sieve adsorbs (physically attracts) the nitrogen from the air as it is pushed through the sieve beds. This allows the oxygen enriched product gas to pass through before being delivered to the pressure regulator. As one tube is generating the product gas, the other is being purged of the adsorbed nitrogen, this process is called pressure swing adsorption (PSA). After passing through the regulator, the rate of product gas is set by the flow meter adjusting valve. Finally, it passes through a fine particle filter (product filter) and then exits the device through a fire-resistant outlet.

## 3 Device Features

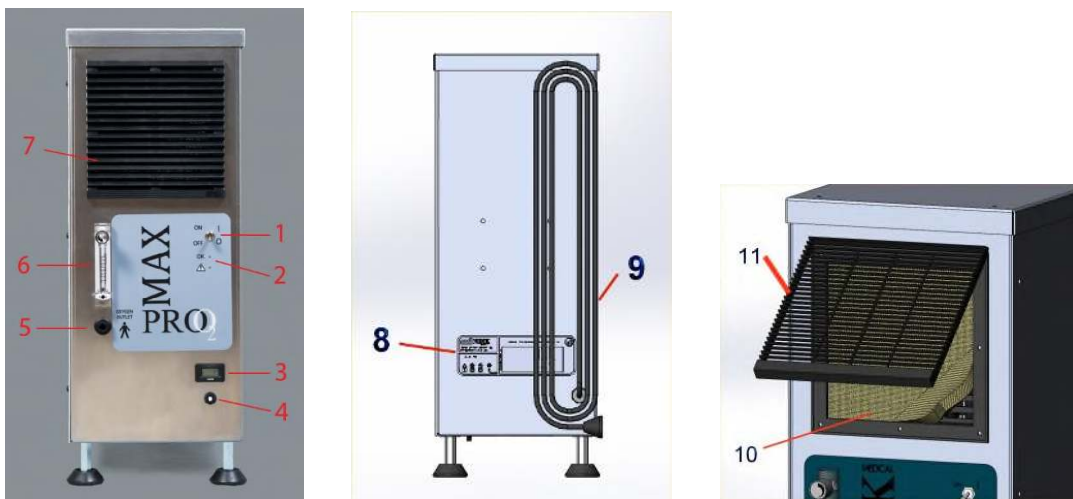

### Features

1. Power Switch (On and Off)
2. Indicator Lights (Ok and Caution)
3. Hour Meter
4. Circuit Breaker
5. Oxygen Outlet
6. Flow Meter (with Adjustment Knob)
7. Intake Ventilation (see 10 & 11 for detailed close up)
8. Technical Label
9. Power Cord
10. Cabinet Air Filter
11. Air Filter Grille

### Accessories

Accessories used with this device must be oxygen compatible and rated for the pressure. The filters notated in this section, available from your distributor, comply with these requirements.

### Filters

Cabinet Air Filter – PN 9600-1053  
Inlet Filter / Element – PN 9800-1027 / 9800-1012  
Filter Kit – PN 9800-1027K (3 Cabinet Filters, 3 Inlet Filter Elements, 1 Product Filter)

## 4 Installation and Operation

The Max Oxygen Generator is packaged to protect the device from damage while being transported and stored. After the device is removed from the package, inspect for damage. If damage is detected, please contact your equipment supplier.

The device should be placed and operated in a space where the Intake Filter Ventilation (7) is not obstructed and the Power Cord (9) is accessible for easy disconnection but does not present a tripping hazard.

To use your device safely, follow the directions below.

1. Ensure that the Power Switch (1) is in the "O" (OFF) position.
2. Ensure the Intake Ventilation (7) is not obstructed or blocked.
3. Plug the Power Cord (9) into an outlet of the correct voltage and frequency as defined on the Technical Label (8).
4. Connect supply tubing, that is rated for oxygen use at the designated pressure, to the Oxygen Outlet (5).
5. Move the Power Switch (1) to the "I" (ON) position.
6. Turn the Flow Adjustment Knob (6) to the desired flow rate.
7. At the end of use, move the Power Switch (1) to the "O" (OFF) position to stop the device.

<input checked="" type="checkbox"/>	The required oxygen concentration is normally obtained within five minutes of the start up of the device.
<input checked="" type="checkbox"/>	The oxygen enriched air flow continues for approximately one minute after shut down of the device.

## 5 Cleaning and Maintenance

Only the outside of the device is to be cleaned. After making sure the Power Switch (1) is in the "O" (OFF) position, use a soft, dry cloth or, if necessary, a damp sponge with mild soap. Do not use acetone, solvents, abrasive powders or any inflammable products to clean the cabinet.

The removable Cabinet Air Filter (10) must be cleaned, at least weekly, in warm water and household detergent. It should be rinsed thoroughly and dried completely before reinstalling. The Inlet Filter / Element (not pictured, located inside the device) should be inspected monthly and replaced if required, or at least annually. The product filter (PN 7631-1053, not pictured, located inside the device) should only be replaced by a technician if required (not common).

## 6 Performance Specifications and Alarm / Safety Features

Model	665MC	765MC	685MC	785MC	695MC	795MC
Description	5LPM 115V	5LPM 230V	8LPM 115V	8LPM 230V	10LPM 115V	10LPM 230V
Frequency	60Hz	50/60Hz	60Hz	50/60Hz	60Hz	50Hz
Average Power	410 Watts	420 Watts	500 Watts	490 Watts	700 Watts	600 Watts
Protection Class	Class I					
Mains Protection	10A	5A	10A	5A	10A	5A
Average Oxygen Content	At 2 LPM > 93% ± 3%		At 2 LPM > 93% ± 3%		At 2 LPM > 93% ± 3%	
Average Oxygen Content	At 5 LPM 87% to 93%		At 8 LPM 87% to 93%		At 10 LPM 87% to 93%	
Liter Flow	1 to 5 LPM		2 to 8 LPM		2 to 10 LPM	
Outlet Pressure	12 Psig		15 Psig		18 Psig	
Dimensions (L x W x H)	508 x 254 x 610 mm (20 x 10 x 24 in.)					
Weight	26 kg (56 lbs.)					

### Indicator Lights and Alarm Conditions

**Green indicator:** This light indicates that power is applied to the concentrator and that it is ready to provide oxygen enriched product gas.

**Yellow indicator:** This light indicates that a system fault has occurred.

**Power Failure detection:** In the event of a loss of power, an intermittent audible alarm is activated (if equipped) and the green light deactivates.

**Process Failure detection:** In the event of a process failure, an audible alarm and the yellow light is activated.

**Electrical Protection:** In the event of a surge or drop in power supply, the circuit breaker will trip. To restart the device, depress the Circuit Breaker button (4).

## 7 Storage and Operating Conditions

The device should be stored in a dry area, with an ambient temperature between -20°C to 60°C (0°F to 140°F) at 15-95% relative humidity. It must be stored, transported and used in the vertical position only. Oxygen concentration can be affected after prolonged periods of storage – check device before use.

The device should be operated in a dry area, with an ambient temperature between 10°C to 40°C (50°F to 105°F) at 15-95% relative humidity. The device can be operated at an altitude of up to 1500m (5000ft) at a temperature of 21°C (70°F) without causing product degradation. Consult your equipment provider for further information regarding 1500m to 4000m (5000ft to 13000ft).

## 8 Disposal

This device has been supplied by an environmentally aware manufacturer. A majority of the parts in the device are recyclable. Follow local governing ordinances and recycling plans regarding disposal of the device or components normally used in operation. Any accessories not original to the device must be disposed of in accordance with the individual product markings for disposal.

## 9 Troubleshooting

OBSERVATIONS	POSSIBLE CAUSES	SOLUTIONS
The Power Switch (1) is in the "I" ON position but the device does not operate.  The audible alarm sounds continuously	Power Cord (9) is not plugged into outlet  Power failure	Check that the device is properly plugged into the electrical outlet  Check the Circuit Breaker (4) and reset if necessary
Yellow Light Indicator (2) remains lit	Product pressure or concentration is not at an acceptable level	Contact your Equipment Supplier
The audible alarm does not sound when device is first turned on	Super capacitors not charged  Internal electrical fault	Leave device plugged in for approximately 10 minutes and retest.  Contact your Equipment Supplier
The device is operating but the Green Light Indicator (2) is not lit	Faulty indicator	Contact your Equipment Supplier
The device is operating but there is no flow (flowmeter ball not moving)	Internal system failure	Stop device immediately and contact your Equipment Supplier
The device is operating but the audible alarm sounds continuously	Internal fault	Stop device immediately and contact your Equipment Supplier
The device suddenly stops and then starts again in a few moments.	Dirty Filters  Compressor Thermal Shut-Off	Clean External Cabinet Filter (10)  Contact your Equipment Supplier
The oxygen flow is interrupted or the flow is irregular	Tubing is disconnected or leaking  Tubing is restricted	Check tubing connections  Straighten tubing  Contact your Equipment Supplier



**Pure Aquatics**  
 Email: [Sales@pureaquatics.com.au](mailto:Sales@pureaquatics.com.au)  
[www.pureaquatics.com.au](http://www.pureaquatics.com.au)