

Small capacity air pump

# HP-20



Pressure type

Outdoor (Rainproof) use

### Applications

- Septic tank (biological contact aeration)
- Bubble bath (air bubble injection)
- Oxygen supply for fish breeding

### Dimensions

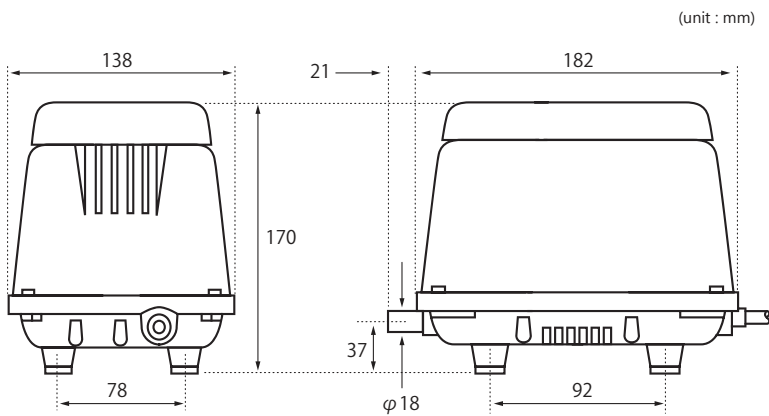

### Specifications

	HP-20	
Rated voltage [ V ]	AC120 / 230	
Power frequency [ Hz ]	50	60
Rated pressure [ kPa ]	9.8	
Airflow volume [ L/min ]	18	20
Power consumption [ W ]	17	
Sound level [ dBA ]	31	
Weight [ kg ]	3.2	

### Performance Curve

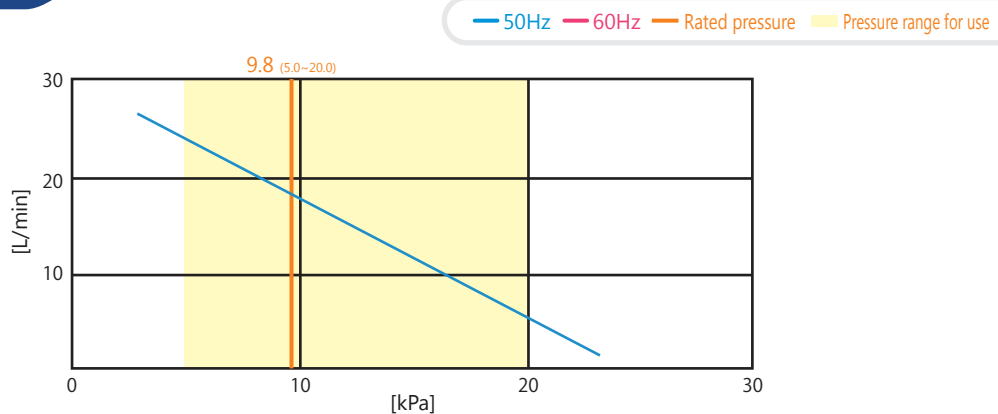

\* All characteristics values are only for reference, and are not guaranteed values.  
\* Note that the operating temperature for our pumps is 41°F(5°C) to 104°F(40°C).